

ZiNiGal-plus[®] and ZiNiGal-plus-light[®]



ZINIGAL PLUS[®], a zinc-nickel alloy containing bismuth, was developed by Boliden to meet the needs of our customers in the general galvanising industry. The easy to use, ready-made alloy means no more mixing of different components, saving our customers time, effort and costs.

In some countries and in some applications, Lead is an unwanted metal. Bismuth is a candidate to replace Lead in order to reduce surface tension. In our ZiNiGal plus[®], we have the right quantity of both Nickel and Bismuth to stabilize your bath at the right concentrations.

By using ZiNiGal plus[®], you improve stability in your galvanising process, improved quality and technical characteristics and at the same time reduce costs

due to the thinner zinc layer resulting in reduced zinc consumption.

OUR PROMISE

Boliden's experienced technical support drives the development and production process of the alloy and our Technical Consultant is ready to answer your questions with regards to your individual application of the product.

Through reliable deliveries, high quality products and professional customer service, including price information and technical support we want to be your supplier of choice.

By becoming Boliden's customer, we want to help you add value to your customers and work with you for a more sustainable future.

ZiNiGal[®] performance

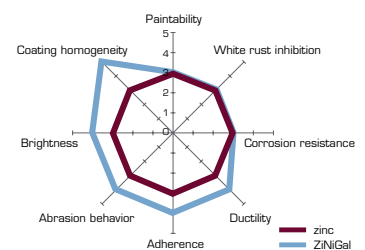

3: standard performance of traditional zinc
 > 3: better performance
 < 3: worse performance

According standard: ISO 1461

Did you know that ...

ZiNiGal[®] helps you decrease zinc consumption by 10 - 15% on average and thus reduce costs.

Technical Specification

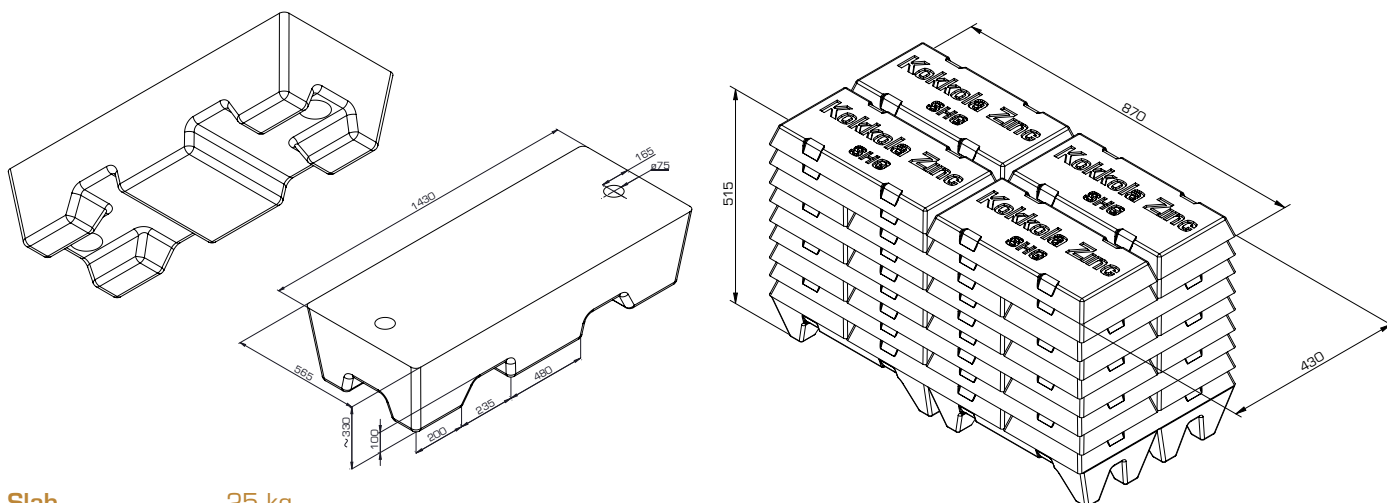

Slab	25 kg	
Slab bundle	1,000 ± 100 kg	870 x 430 x 515 mm
Jumbo 1,400 kg	1,400 ± 100 kg	1,440 x 576 x 335 mm

Chemical composition	Guaranteed analysis	Tolerance
Ni	0.15 % or 0.12 %*	± 0.03 %
Bi	0.05 %	± 0.01 %
Pb	≤ 0.005 %	
Cd	≤ 0.005 %	
Fe	≤ 0.005 %	
Al	≤ 0.005 %	
Sn	≤ 0.002 %	
Cu	≤ 0.001 %	

Physical property	Unit	Value
Density solid	g/cm ³	7.14
Density liquid (melting temperature)	g/cm ³	6.62
Melting point	°C	419
Boiling point	°C	907
Surface tension (420 °C)	N/m	0.78
Viscosity (420 °C)	N/m	0.00385
Melting enthalpy	kJ/kg	100
Thermal capacity (solid)	J/kg K	388
Thermal capacity (liquid)	J/kg K	560

*(respectively)

The Boliden Group

Metals are an ever-present and vital component of society. Boliden extracts minerals and produces high quality metals in a cost-efficient way. The work – from exploration to customer delivery – is characterised by care for people, the environment and society.

The Boliden Group operates six mines and five smelters in Sweden, Finland, Norway and Ireland and has a total of approximately 5,700 employees. Our core expertise is in exploration, mining, smelting and recycling.

Boliden's main metals are zinc and copper, but the production of lead, nickel, gold, silver and other products is also of considerable importance for our profitability. The annual turnover is approximately SEK 50 billion.



Our value chain

Exploration Successful exploration is vital to long-term metal production. The exploration is conducted in the vicinity of existing mines and in new areas in order to find new deposits.

Mines Zinc-, copper-, nickel-, lead-, gold- and silver-bearing ores are mined in Boliden's mining areas. The ore is processed to metal concentrate, the majority of which is delivered to smelters within the Group.

Smelters Boliden's smelters refine metal concentrates and other raw materials, such as electronic scrap, to produce both pure metals and customised alloys.

Customers Our products are mainly sold to industrial customers in Europe. Most of the zinc is sold to steel companies, while the copper is supplied to manufacturers of for example wire rod.