



**REFINED LEAD INGOTS** are produced from scrapped batteries and other lead-containing recyclables at Bergsöe, one of Boliden's five smelters, located in Landskrona Sweden. The smelter is the only secondary lead smelter in the Nordics and has a strategic location for sourcing material and serving customers in Europe. Bergsöe has a production capacity of approximately 50,000 metric tonnes lead per year.

Boliden Bergsöe's lead content is minimum 99.97% and is LME approved under the brand name BERA. In addition, Bergsöe produces lead alloys with antimony, calcium and tin. Our lead alloys are tailored to customer-specific requirements and the process is subject to extensive analyses.

**OUR PROMISE**

With a strong customer commitment we want to ensure you receive lead which meets your needs in quality.

On time deliveries are a natural part of our promise to support you in your production planning.

Sustainability is an integral part of Boliden's operations and management. The basis for this work is that all of our operations are conducted in accordance with legislative provisions and permits in the countries in which we operate.

By becoming Boliden's partner, we want to help you add value to your customers and work with you for a more sustainable future.



**Brussels nomenclature 78011000**

**Did you know that ...**

The majority of Boliden's lead production is sold to the battery industry, with a smaller percentage sold to the construction industry.

# Technical Specification BERA

<b>Ingot shape:</b>	<b>max.</b> 627 x 121 x 84 mm
<b>Ingot weight:</b>	45 kg
<b>Unit load:</b>	25 pigs secured by two straps
<b>Unit shape:</b>	627 x 627 x 420 mm
<b>Unit weight:</b>	1 150 kg
<b>Unit volume:</b>	0,154 m <sup>3</sup>
<b>Ingot marking:</b>	Brand name BERA
<b>Unit marking:</b>	Weight, cast, article and sequence number
<b>Physical properties:</b>	Melting point 327,5 °C

Chemical composition	Type analysis	Maximum tolerance
Bi	250	ppm
Ag	30	ppm
As	10	ppm
Cd	10	ppm
Cu	10	ppm
Ni	5	ppm
Sb	10	ppm
Sn	10	ppm
Te	7	ppm
Tl	10	ppm
Zn	5	ppm

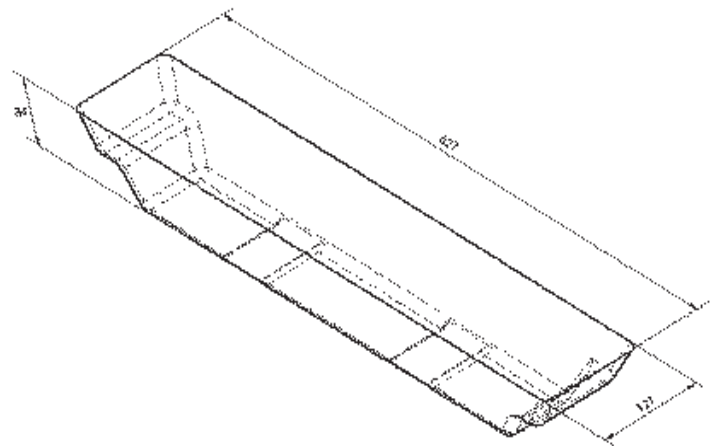
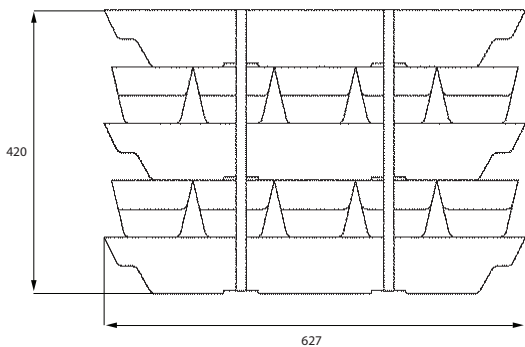

## The Boliden Group

Metals are an ever-present and vital component of society. Boliden extracts minerals and produces high quality metals in a cost-efficient way. The work – from exploration to customer delivery – is characterised by care for people, the environment and society.

The Boliden Group operates six mines and five smelters in Sweden, Finland, Norway and Ireland and has a total of approximately 5,700 employees. Our core expertise is in exploration, mining, smelting and recycling.

Boliden's main metals are zinc and copper, but the production of lead, nickel, gold, silver and other products is also of considerable importance for our profitability. The annual turnover is approximately SEK 50 billion.



## Our value chain

**Exploration** Successful exploration is vital to long-term metal production. The exploration is conducted in the vicinity of existing mines and in new areas in order to find new deposits.

**Mines** Zinc-, copper-, nickel-, lead-, gold- and silver-bearing ores are mined in Boliden's mining areas. The ore is processed to metal concentrate, the majority of which is delivered to smelters within the Group.

**Smelters** Boliden's smelters refine metal concentrates and other raw materials, such as electronic scrap, to produce both pure metals and customised alloys.

**Customers** Our products are mainly sold to industrial customers in Europe. Most of the zinc is sold to steel companies, while the copper is supplied to manufacturers of for example wire rod.