

# ZiNiGal-bright<sup>®</sup> and ZiNiGal-light-Bright<sup>®</sup>



**ZINIGAL BRIGHT<sup>®</sup>**, a zinc-nickel alloy, was developed by Boliden to meet the needs of our customers in the general galvanising industry. The easy to use, ready-made alloy means no more mixing of different components, saving our customers time, effort and costs.

By adding nickel to your zinc bath, most technical characteristics are improved. You can simply replace the zinc in your bath with ZiNiGal-bright<sup>®</sup> without any change to your production process.

In some countries and in some applications, Lead is an unwanted metal. Bismuth is a candidate to replace Lead in order to reduce surface tension. In our ZiNiGal bright<sup>®</sup>, we have the right

quantity of both Nickel and Bismuth to stabilize your bath at the right concentrations.

Additions of Tin further enables a good wettability of the steel work in the liquid Zinc and therefore reduces surface defects and improves the overall aspect.

By using ZiNiGal bright<sup>®</sup>, you improve stability in your galvanising process, improved quality and technical characteristics and at the same time reduce costs due to the thinner zinc layer resulting in reduced zinc consumption.

#### **OUR PROMISE**

Boliden's experienced technical support drives the development and production process of the alloy and our Techni-

cal Consultant is ready to answer your questions with regards to your individual application of the product.

Through reliable deliveries, high quality products and professional customer service, including price information and technical support we want to be your supplier of choice.

By becoming Boliden's customer, we want to help you add value to your customers and work with you for a more sustainable future.

# Technical Specification

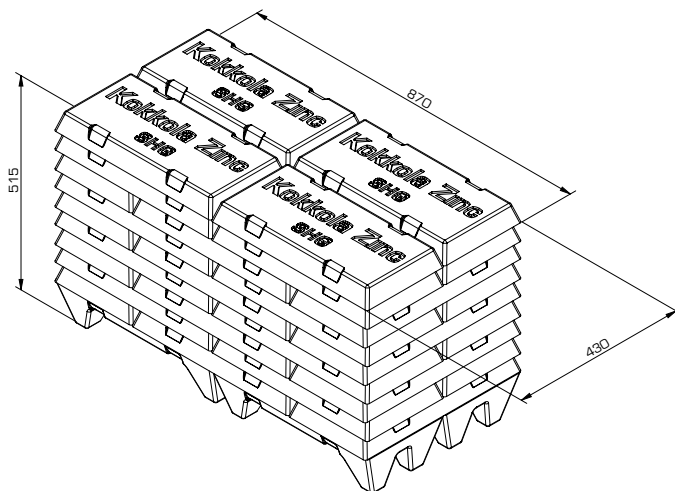
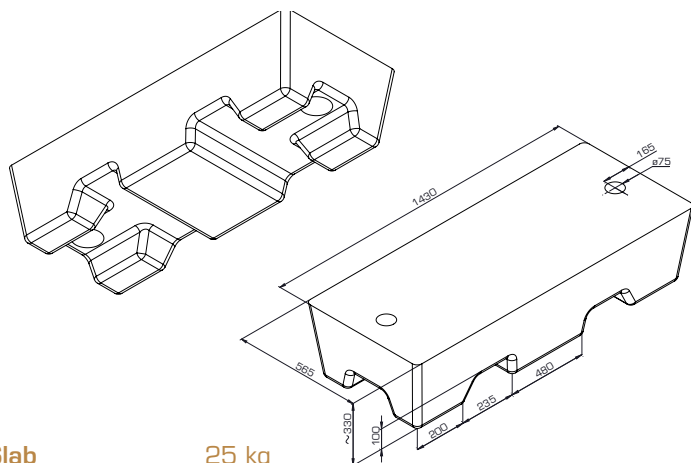

**Slab** 25 kg  
**Slab bundle** 1,000 ± 100 kg 964 x 482 x 396 mm  
**Jumbo 1,400 kg** 1,400 ± 100 kg 1,440 x 576 x 335 mm

	ZiNiGal-Bright®	Tolerance
Alloying metals		
Ni	0,15% or 0,12%	±0,03%
Bi	0,05%	±0,01%
Sn	0,05%	±0,01%
Al	<0,005%	
Cu	<0,001%	
Cd	<0,003%	
Fe	<0,005%	
Pb	<0,005%	

\*(respectively)

Physical property	Unit	Value
Density solid	g/cm <sup>3</sup>	7.14
Density liquid (melting temperature)	g/cm <sup>3</sup>	6.62
Melting point	°C	419
Boiling point	°C	907
Surface tension (420 oC)	N/m	0.78
Viscosity (420 °C)	N/m	0.00385
Melting enthalpy	kJ/kg	100
Thermal capacity (solid)	J/kg K	388
Thermal capacity (liquid)	J/kg K	560

## The Boliden Group

Metals are an ever-present and vital component of society. Boliden extracts minerals and produces high quality metals in a cost-efficient way. The work – from exploration to customer delivery – is characterised by care for people, the environment and society.

The Boliden Group operates six mines and five smelters in Sweden, Finland, Norway and Ireland and has a total of approximately 5,700 employees. Our core expertise is in exploration, mining, smelting and recycling.

Boliden's main metals are zinc and copper, but the production of lead, nickel, gold, silver and other products is also of considerable importance for our profitability. The annual turnover is approximately SEK 50 billion.



## Our value chain

**Exploration** Successful exploration is vital to long-term metal production. The exploration is conducted in the vicinity of existing mines and in new areas in order to find new deposits.

**Mines** Zinc-, copper-, nickel-, lead-, gold- and silver-bearing ores are mined in Boliden's mining areas. The ore is processed to metal concentrate, the majority of which is delivered to smelters within the Group.

**Smelters** Boliden's smelters refine metal concentrates and other raw materials, such as electronic scrap, to produce both pure metals and customised alloys.

**Customers** Our products are mainly sold to industrial customers in Europe. Most of the zinc is sold to steel companies, while the copper is supplied to manufacturers of for example wire rod.