

# Norzak



**NORZAK** is a Zinc-based die-cast-alloy especially developed for hot chamber die-casting. The applied Aluminium-concentration grants best fluidity and excellent impact strength.

The applied Copper-concentration, further increase strength of casted part by keeping the dimensional stability. Finally, the Magnesium provides additional strength and inhibits intergranular corrosion of the casted part.

All in all, NORZAK 5 offers the best compromise for die-casted parts with regard to mechanical properties, enabling a near to shape casting and reducing post treatment works to a minimum. Norzak 5 is produced in 7 kg waffles and solidifies around 380 °C.

#### OUR PROMISE

Boliden's experienced technical support drives the development and production process of the alloy and our Technical Consultant is ready to answer your questions with regards to your individual application of the product.

Through reliable deliveries, high quality products and professional customer service, including price information and technical support we want to be your supplier of choice.

By becoming Boliden's customer, we want to help you add value to your customers and work with you for a more sustainable future.



**Standards: ISO 301, EN 1774**  
**Grade: Norzak 5 ZL 0410, Norzak 3 ZL0400**

### Did you know that ...

Boliden is the world's fifth largest producer of zinc metal from smelters.

# Technical Specification NORZAK

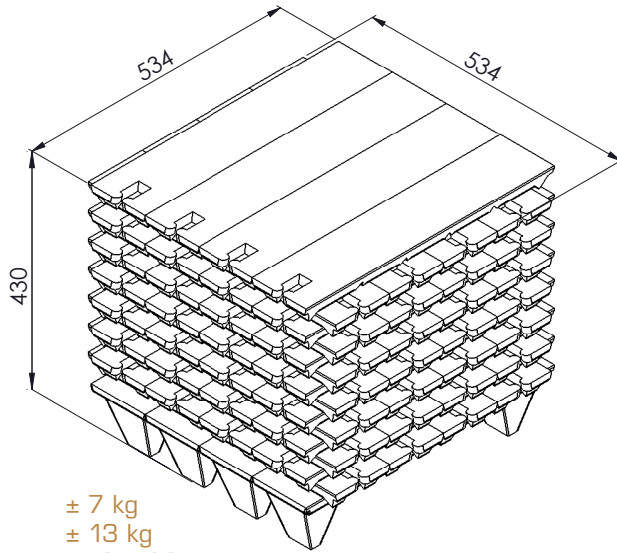

**Slab** ± 7 kg  
**Feey** ± 13 kg  
**Slab bundle** 440 ± 20 kg

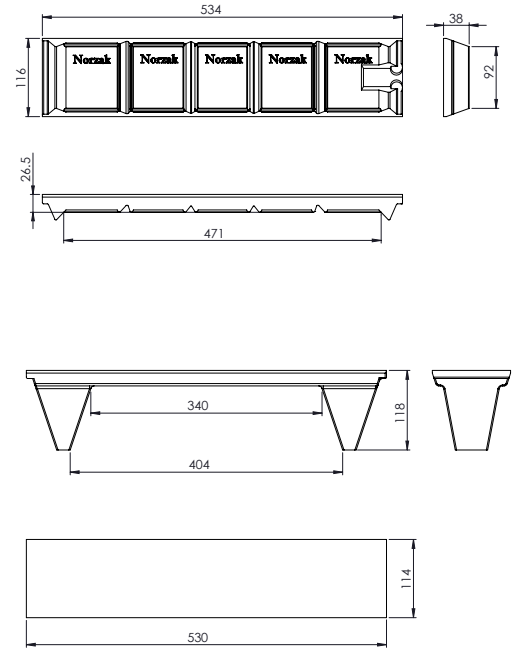

Chemical composition	NORZAK 5	NORZAK 3
Al	3.8 – 4.2 %	3.8 – 4.2 %
Cu	0.7 – 1.1 %	-
Mg	0.035 – 0.06 %	0.035 – 0.06 %

Impurities	NORZAK 5	NORZAK 3
Cu	-	≤ 0.03 %
Cd	≤ 0.003 %	≤ 0.003 %
Fe	≤ 0.02 %	≤ 0.02 %
Pb	≤ 0.003 %	≤ 0.003 %
Ni	≤ 0.001 %	≤ 0.001 %
Si	≤ 0.02 %	≤ 0.02 %
Sn	≤ 0.001 %	≤ 0.001 %

## The Boliden Group

Metals are an ever-present and vital component of society. Boliden extracts minerals and produces high quality metals in a cost-efficient way. The work – from exploration to customer delivery – is characterised by care for people, the environment and society.

The Boliden Group operates six mines and five smelters in Sweden, Finland, Norway and Ireland and has a total of approximately 5,700 employees. Our core expertise is in exploration, mining, smelting and recycling.

Boliden's main metals are zinc and copper, but the production of lead, nickel, gold, silver and other products is also of considerable importance for our profitability. The annual turnover is approximately SEK 50 billion.



## Our value chain

**Exploration** Successful exploration is vital to long-term metal production. The exploration is conducted in the vicinity of existing mines and in new areas in order to find new deposits.

**Mines** Zinc-, copper-, nickel-, lead-, gold- and silver-bearing ores are mined in Boliden's mining areas. The ore is processed to metal concentrate, the majority of which is delivered to smelters within the Group.

**Smelters** Boliden's smelters refine metal concentrates and other raw materials, such as electronic scrap, to produce both pure metals and customised alloys.

**Customers** Our products are mainly sold to industrial customers in Europe. Most of the zinc is sold to steel companies, while the copper is supplied to manufacturers of for example wire rod.